

## <JDT-128> Specification

- Note:1.The dimension of motor can e BL or BR  
 2.We install the sensor outside.(right or left side) (optional accessory)  
 3.Applicable motor:100,200W,400W.

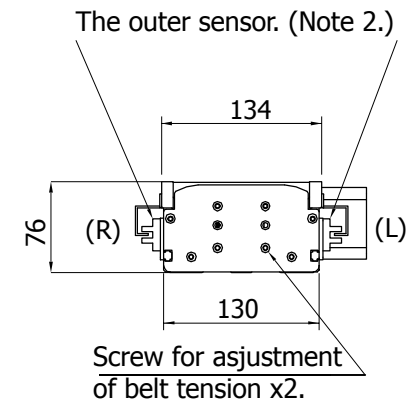

- SENSOR Operation:  
 1.+LS  
 2.HOME  
 3.-LS

Unit:mm

Stroke	300	400	500	600	700	800	900	1000	1100	1200	1300	1400	1500	1600	1700	1800	1900	2000
L	552	652	752	852	952	1052	1152	1252	1352	1452	1552	1652	1752	1852	1952	2052	2152	2252
A	2	2	3	3	4	4	5	5	6	6	7	7	8	8	9	9	10	10
B	50	150	50	150	50	150	50	150	50	150	50	150	50	150	50	150	50	150
N	8	8	10	10	12	12	14	14	16	16	16	18	20	20	22	22	24	24
Weight(kg)	8.3	9.5	11.7	12.9	14.1	15.3	16.5	17.7	18.9	20.1	20.7	21.3	21.9	22.5	23.1	23.7	24.3	24.9