

<JDTN-80> Specification

- Note:1.We install the sensor outside.(right or left side)(optional accessory)
 2.The dimension of machine changes according to different motor.
 3.Applicable motor:100W or less than 100W.

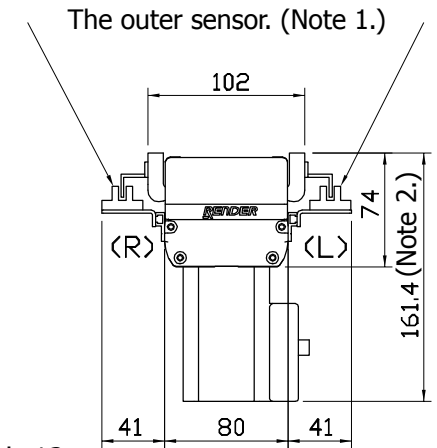
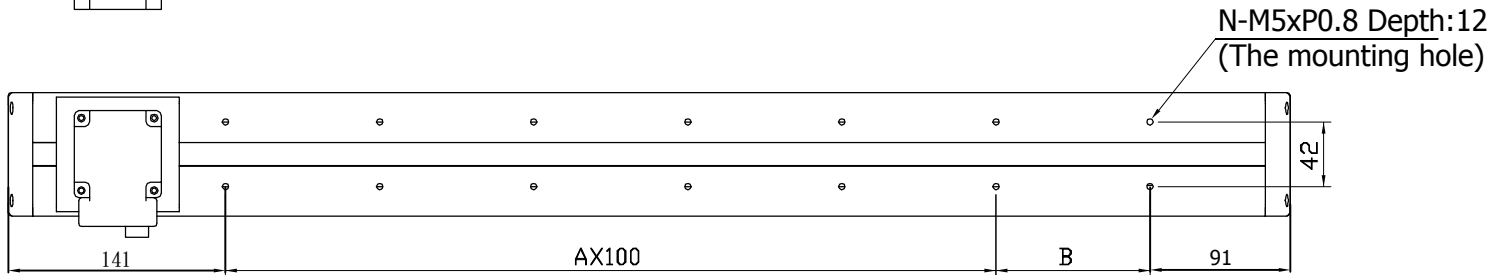
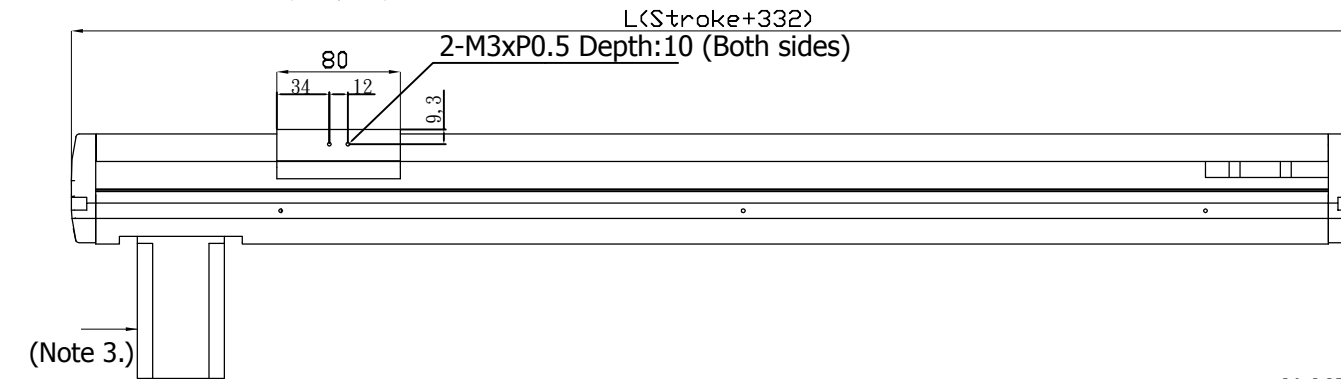
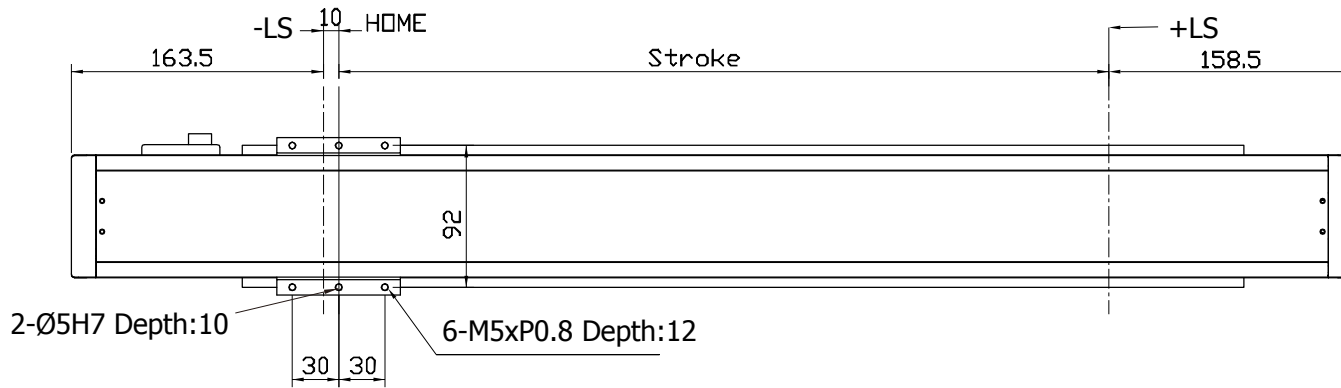

SENSOR Operation:
 1.+LS
 2.HOME
 3.-LS

Unit:mm

Stroke	100	200	300	400	500	600	700	800	900	1000	1100	1200
L	432	532	632	732	832	932	1032	1132	1232	1332	1432	1532
A	1	2	3	4	5	6	7	8	9	10	11	12
B	100	100	100	100	100	100	100	100	100	100	100	100
N	6	8	10	12	14	16	18	20	22	24	26	28
Weight(kg)	3.1	4.3	5.5	6.7	7.9	9.1	10.3	11.5	12.1	12.7	13.3	13.9